

Low Glare Recessed LED Downlight

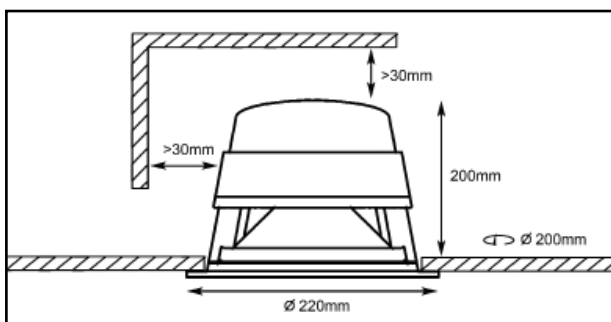

Dimensions



Photometric IES file available from www.truelux.co.uk

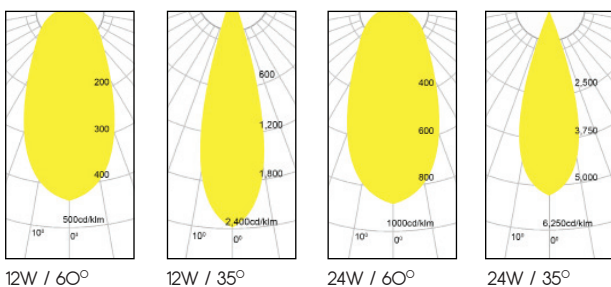

Accessories

- Emergency backup – maintained /BM or non maintained /BNM
- Glass Halo – frosted /GHF
- Glass Diffuser (IP54) – frosted /GDF or clear /GDC

Product code

Model	Brightness	Colour temp	Beam	Colour	Driver	Accessory
LMX	24	2800	35	WH	PH	BM

Details

- Recessed lamp design suitable for commercial and retail spaces
- Low glare reflector UGR <19
- 2 light engine options / 24W or 12W
- 220mm diameter
- White, black or brown finish
- Replaceable light engine
- Replaceable dimmable driver
- CRI >85
- Patented ELR convection heatsink technology
- Meets L1 and L2 2010 UK building regulations
- Lifetime of 50000 hrs / 3 year guarantee¹

Options

Brightness 24W, 1200lm²
 Colour temp 2800K / 3000K / 4500K
 Beam angle 20° / 35° / 60°
 Colour White / Black / Brown
 Size 220mm (9") diameter
 Driver Phase / DALI / 1-10V dimming (110/240V)
² 1300lm @ 4500K

Brightness 12W, 650lm³
 Colour temp 2800K / 3000K / 4500K
 Beam angle 20° / 35° / 60°
 Colour White / Black / Brown
 Size 220mm (9") diameter
 Driver Phase / DALI / 1-10V dimming (110/240V)
³ 700lm @ 4500K



IEC62031 IEC60598-1

Equivalent

- 24W – 100W halogen, 52W CFL, 35W metal halide
 12W – 50W halogen, 26W CFL, 20W metal halide

Precautions

Ensure of adequate ventilation for light engine heatsink
 Disconnect mains before installation
¹warranty void if not fitted according to directions